



ZX Outdoor Vacuum Reclosers 15-38 kV

Automatic Vacuum Recloser

Introduction & Benefits

Pomanique's ZX-Series three-phase, electronically controlled, vacuum- interrupting distribution automation switch provides reliable, economical switching, sectionalizing, advanced metering, and automation systems for distribution circuits rated up to 38 kV.

The ZX switch combines solid cycloaliphatic- epoxy vacuum interrupters with a reliable, lightweight operating mechanism that utilizes a magnetic actuator to provide a lifetime of trouble- free operation. The solid polymer system does not rely on a gaseous, liquid, or foam dielectric. The ZX switch is highly resistant to ozone, oxygen, moisture, contamination, and ultraviolet light.

Switch operations are programmed in an electronic control with accurate characteristics and a host of advanced features. When system requirements change, program settings are easily altered with no sacrifice of accuracy or consistency.

Pomanique's reclosers meet all the requirements for outdoor use in accordance with the IEEE C37.60 and IEC 62271-111.

Long life and low maintenance

- Magnetic actuators and superior design allow pomanique's reclosers to operate for a rated 10,000 full load operations.
- Less moving parts = less maintenance for 25 years.

High reliability

- Pomanique designed a simple, magnetically actuated operating mechanism that could dependably operate with only one moving part.
- Vacuum interrupter technology make ZX recloser with maximum reliability and minimal maintenance.
- Environmentally friendly.

Optimized Measurement

- Reclosers are equipped with current transformer and voltage sensors in each bushings to measure current and voltage, It makes the recloser an ideal device for self-healing loop automation solutions.

Microprocessor based controller

- Controller provides more enhanced functions in protection, monitoring, metering, communication and recorder, and can also support your power distribution system to be more reliable.



15.5kV & 27kV Switch unit



38kV Switch unit



Controller

Automatic Vacuum Recloser

Switch unit description

Recloser principle

Reclosers are used in overhead lines and in substations. Like circuit-breakers they are capable of switching normal and fault currents. They are equipped with sensors and controller being the protection and control device. In case of a temporary line fault, they can trip and reclose up to four times, thus avoiding longer network interruptions.

Recloser cycle

In case of a network fault, the recloser opens and recloses several times. In case of temporary faults, the automatic reclosing significantly reduces the outage times.

While the trip settings for each operation can be set individually.

Design of switch unit

Each vacuum interrupter is embedded in a solid-insulated pole made of weather-proof cycloaliphatic epoxy-resin. The vacuum interrupter is vertically mounted inside the pole, providing a long service life. Each pole is equipped with an integrated current transformer and a resistive voltage sensor.

Operating mechanism

The recloser is operated by a magnetic actuator, the actuator is a bi-stable system, locked in the end positions by permanent magnets. If not in operation, the magnet coils do not consume any power.

The operating mechanism housing is made of stainless steel for outdoor applications. It also accommodates the position indicator and a mechanical operations counter.

Mechanical lockout

The recloser can be tripped manually. If the handle is pulled, the recloser opens and is simultaneously locked out electrically and mechanically. The handle stays extended, thus indicating the interlocked state.

To close the recloser again, the handle must first be pushed back to the operation position in order to release the lockout. Then the recloser can be closed electrically via the controller.



Lockout handle-pulled (open position)



Lockout handle-push in (close position)

Automatic Vacuum Recloser

Controller description

Controller

The Microprocessor Based controller provide protection, control, monitoring, instrumentation and metering with integrated input and output logic, data logging & fault reports.

Communication access to controller functionality is via electrical RS485 port for remote connection. Additional rear port options including RS232 port is available.

The controller is mounted in the control cubicle. Along with the controller, this cubicle also contains the auxiliary power supply with batteries for uninterruptible power supply, electronic boards and circuit breakers.

The controller contains a large number of protection functions (elements) which can be selected or deselected through the menu driven display.

Enhanced features

- Analysis of current/voltage normal & negative sequence for power quality monitoring.
- Recording of PQM with fault waveform of 128 sampling and 20 cycles.
- Harmonics analysis of electric data.

Monitoring of Sag, Swell, Interruption, over & low voltage, unbalance and etc.

- Improvement of fault detection algorithm.
- Automatic isolation of faulted section site and interconnection with other healthy section.
- Improved measuring accuracy.
- Multi-Protocol support. (DNP3.0, MODBUS, IEC60870-5-101/104 & IEC61850).
- User programmable logic(PLC) support.

Cubicle

The cubicle includes the complete electronics, the protection relay and the UPS system of the recloser. Additional components and features can be selected via order.

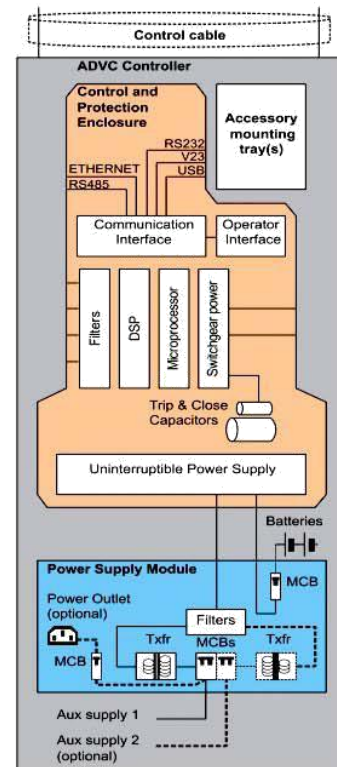

Automatic Vacuum Recloser

General Protection Features

Operating sequence

Reclose times are selectable. The operating sequence is defined by:

O - 1st rt - CO - 2nd rt - CO - 3rd rt - CO

Reclose times

- 1st Reclose Time range: 0.3 - 600 sec
- 2nd Reclose Time range: 2.0 - 600 sec
- 3rd Reclose Time range: 2.0 - 600 sec
- Timing resolution: 0.1 sec

Sequence reset time

- Sequence Reset Time: 3 - 180 sec
- Timing resolution: 1 sec

Trips to lockout

Overcurrent and fault trips to lockout are selectable between 1 and 4. A separate setting is available for Sensitive Earth Fault and Negative Phase Sequence.

Inverse time curves

Three IEC60255 curves:

Inverse,
Very Inverse
Extremely Inverse.

Three IEEE C37.112 Inverse Time curves:

Moderately Inverse
Very Inverse
Extremely Inverse

Non Standard Inverse Time Curves: Refer to the Operating

Manual for a full listing.

Instantaneous protection

Instantaneous protection works by tripping the recloser if the line current exceeds the Instantaneous Multiplier x Setting Current.

Definite time protection

Definite Time is an alternative to Inverse Time protection. It works by tripping the recloser at a fixed time after pick-up.

- Setting current range: 10 - 1260A
- Definite time resolution: 0.1 sec
- Definite time range: 0.01 - 100 sec
- Setting current resolution: 1A

Sensitive earth fault

The recloser trip when the earth current rises above a set level for longer than the set time.

- Trip current range: 4 - 20A
- Operating time range: 0.1 - 999 sec
- Trip current setting resolution: 1 A
- Operating time resolution: 0.1 sec

Inrush restraint

Inrush restraint raises the phase and earth threshold currents for a short period of time to allow for short duration inrush currents when closing onto a load.

- Multiplier range: 1 - 30
- Multiplier resolution: 0.1
- Time range: 0.05 - 30 sec
- Time resolution: 0.05 sec

Zero sequence protection

Negative, positive and zero phase sequence currents and voltages can be monitored and logged.

In addition, the negative phase sequence current protection can be used for detection of low-level phase-to-phase faults in the presence of high level

- three phase loads. Inverse Time, Definite Time and
- Instantaneous operation is available.

Under / over voltage protection

Under Voltage Lower Threshold Range: 50% - 88%

Over Voltage Upper Threshold Range: 112% - 150%

Directional protection

Distinct protection for faults in the forward and reverse direction. A forward fault may use a different time-current curve and settings to a reverse fault (i.e. these are individually selectable). Both the forward protection and reverse protection are operating at the same time. This is an additional protection feature.

Automatic Vacuum Recloser

Technical data

15.5kV 50/60Hz	Rated continuous current	Rated duration of short-circuit	Rated short-circuit breaking current	Rated short-circuit making current	Rated lightning impulse withstand voltage	Rated short-duration P.F. withstand voltage	Impedance $\mu\Omega$ between connections	Creepage distance, phase-to-earth	Clearance, phase-to-phase	Minimum clearance, phase-to-earth	Weight	Line charging current	Cable charging current	Max. interrupting time / max. closing time
	I _r A	T _k s	I _{sc} kA	I _{ma} kA	U _p kV	U _d kV	$\mu\Omega$	mm	mm	mm	kg	A	A	ms
ZX15-630-12-N	630	3	12.5	31.5	110	50	50	850	320	270	130	2	10	60/60
ZX15-800-12-N	800	3	12.5	31.5	110	50	50	850	320	270	130	2	10	60/60
ZX15-630-16-N	630	3	16	40	110	50	50	850	320	270	130	2	10	60/60
ZX15-800-16-N	800	3	16	40	110	50	50	850	320	270	130	2	10	60/60

27kV 50/60Hz	I _r A	T _k s	I _{sc} kA	I _{ma} kA	U _p kV	U _d kV	$\mu\Omega$	mm	mm	mm	kg	A	A	ms
	ZX27-630-12-N	630	3	12.5	31.5	125	60	50	850	320	270	140	5	25
ZX27-800-12-N	800	3	12.5	31.5	125	60	50	850	320	270	140	5	25	60/60
ZX27-630-16-N	630	3	16	40	125	60	50	850	320	270	140	5	25	60/60
ZX27-800-16-N	800	3	16	40	125	60	50	850	320	270	140	5	25	60/60
ZX27-630-16-H	630	3	16	40	150	70	50	1290	320	350	150	5	25	60/60
ZX27-800-16-H	800	3	16	40	150	70	50	1290	320	350	150	5	25	60/60

38kV 50/60Hz	I _r A	T _k s	I _{sc} kA	I _{ma} kA	U _p kV	U _d kV	$\mu\Omega$	mm	mm	mm	kg	A	A	ms
	ZX38-630-12-N	630	3	12.5	31.5	150	70	50	1290	320	350	150	5	40
ZX38-800-12-N	800	3	12.5	31.5	150	70	50	1290	320	350	150	5	40	60/60
ZX38-630-16-N	630	3	16	40	150	70	50	1290	320	350	150	5	40	60/60
ZX38-800-16-N	800	3	16	40	150	70	50	1290	320	350	150	5	40	60/60

Automatic Vacuum Recloser

Dimension drawings

		A	B	C	D	E	F
15.5kV	mm	460	380	850	508	270	970
27kV	mm	460	380	850	508	270	970
38kV	mm	512	380	970	590	270	970

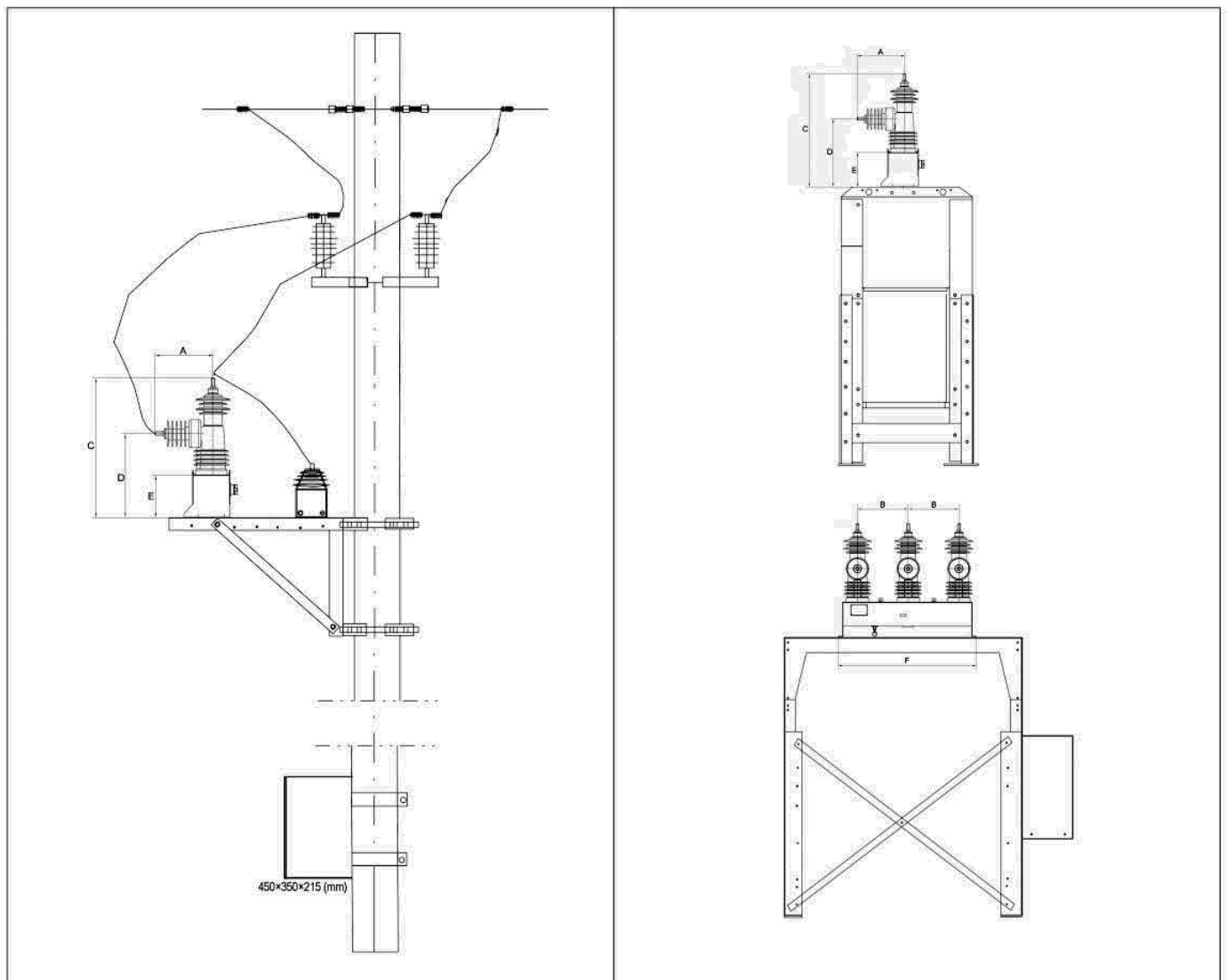

Pole mount

Substation mount